



COCHIN PORT TRUST

COCHIN-682009, KERALA, INDIA

Tele: 91-0484-2666414, 2666871

Telefax: 91-0484-2666414

E-mail:coptce@gmail.com

E-QUOTATION DOCUMENT FOR CLEANING THE PERIPHERAL RCC DRAIN  
ALONGSIDE OF M/S.PETRONET LNG, BPCL AND IOC AT PUTHUVYPEEN  
INCLUDING DISPOSING THE SILT / DEBRIS UP TO 4 KM LEAD

Website:[www.tenderwizard.com/CoPT](http://www.tenderwizard.com/CoPT)

EXE. ENGINEER(CM-I)'S OFFICE

COCHIN PORT TRUST

COCHIN-682009

QUOTATION No.T1/Q-20/2020-C

## **I. GENERAL CONDITIONS**

1. The work under this contract covers Cleaning the peripheral RCC drain alongside of M/s. Petronet LNG, BPCL and IOC at Puthuvypeen including disposing the silt / debries up to 4 Km lead.
2. The bidders need to obtain the one time User ID & password for log-in to e-tendering Portal [www.tenderwizard.com/COPT](http://www.tenderwizard.com/COPT) from the service provider M/s. KEONICS by paying registration amount of Rs.1124/- through online Payment using Credit/Debit Card/Net banking or DD in favour of “KSEDCL, Bangalore”.
3. The intending bidder must have valid Class-II or III digital signature certificate to submit the bid. For further details, please contact e-Tender Help Desk No. 080-40482000/ 080-49352000/ 9746118529/ 9605557738.
4. e-Quotations are invited from the Registered contractors of Cochin Port as well as firms specialized in doing Pest control operations as approved by CoPT.
5. The Quotationer shall submit the Quotation Notice, General conditions & Schedule of Quantities of work ‘**Online**’. The name and address of the quotationers shall be necessarily entered in the space provided in the Schedule of Quantities of Work.
6. The Quotationer shall inspect the site before submitting the quotation in order to make them fully aware of the site and its conditions.
7. Clarifications if any required can be obtained by contacting the Asst. Exe. Engineer/ Asst. Engineer of concerned Civil section.
8. The period of contract is 1 month from the date of commencement of the work.
9. The Engineer-in-Charge of the work (Engineer’s Nominee/ Nominee) shall be Exe. Engineer (CM-I).
10. **Water & Electricity**  
**Water:** Water, if required for the work, shall be arranged by the Quotationer at his own cost.  
**Electricity:** The Quotationer shall make his own arrangements for electricity required.
11. The rate/percentage quoted shall be excluding Goods & Service Tax (GST).
12. The Quotationer shall have valid GST Registration number. GST as applicable for the work will be paid extra by the Port. The GST applicable as per law can be billed on the Port Trust, which will be paid to the Quotationer by the Board along with the bills, for which the Quotationer shall hold valid GST Registration number.

13. All labour, skilled or unskilled for the work shall be provided by the Quotationer at his own cost and settling any disputes with the labour shall be, Quotationer's responsibility.
14. All care and precautionary measures for avoiding any kind of damage/accidents in the work site shall be taken by the Quotationer. All safety precautions shall be taken while carrying out the work. The Quotationer shall supply the necessary safety equipments to the workers employed by him and also ensure that they use it, while carrying out the work. The Quotationer shall be solely liable and responsible for accidents if any, occurring during the period of Contract.
15. The work shall be completed without causing any damage to the existing structures/cables etc. In case any damage is caused, the same has to be rectified at Quotationer's risk and cost.
16. The Port will in no way be responsible for any loss/damages caused in connection with the work.
17. The quantities specified in the schedule of quantities of work are only approximate and shall be increased or decreased at the discretion of the Engineer-in-Charge according to actual requirements. Payment will be made as per actual measurements, according to the percentage quoted.
18. Quotations shall be valid for a period of 60 days from the due date of submission of quotation.
19. **Liquidated Damages:** In case of delay in completion of the contract, liquidated damages (L.D) may be levied at the rate of half percent (½%) of the Contract Price per week of delay, subject to a maximum of 10% of the Contract Price. The amount of Liquidated Damages can be adjusted or set-off against any sum payable to the Quotationer.
20. **Security Deposit:** Security deposit @ 5% of Contract Price or value of work done whichever is higher shall be recovered from the Quotationer's bill. The amount towards Security Deposit so deducted will be released to the contractor within 14 days from the date of payment of final bill.
21. **Execution of Agreement:** The successful Quotationer will be required to execute **within 5 days from the date of receipt of work order**, an agreement at his expense on proper value Kerala State Stamp Paper in the prescribed departmental form, consisting of the work order issued to the Quotationer, together with the Quotation submitted by him including General Conditions, for the due and proper fulfilment of the contract.
22. Till signing of agreement, the Quotation together with the acceptance letter shall constitute a binding contract between the Quotationer and Cochin Port.

23. The Contractor shall comply with all the provisions of the Indian Workmen's Compensations Act, Public Liability Policy, Provident Fund Regulations, Employees Provident Fund and ESI Act etc. amended from time to time and rules framed there under and other laws affecting the Contract labour that may be brought in to force from time to time.
24. The Contractor shall be registered under EPF and ESI act and the employees employed under them shall be covered in the EPF and ESI Scheme, if required as per applicable rules. The Contractors shall regularly remit, the Employer & Employee contribution to the authorities in such cases. If not, the Dept. would be required to remit the same and the amount so remitted shall be deducted from the part/ final bill of Contractors.

**SIGNATURE OF QUOTATIONER.**

**II. DETAILED SPECIFICATIONS CLEANING THE PERIPHERAL RCC DRAIN ALONGSIDE OF M/S.PETRONET LNG, BPCL AND IOC AT PUTHUVYPEEN INCLUDING DISPOSING THE SILT / DEBRIS UP TO 4 KM LEAD.**

**GENERAL**

- 1. The work consists of cleaning and maintaining the peripheral RCC drain alongside of M/S.Petronet LNG, BPCL and IOC at Puthuvypeen including disposing the silt / debris up to 4 km lead by cutting/ removing the weeds, grass etc. from the sides, removing the silt from the bottom and clearing the side berms by stripping, from the road edge up to drain edge on both sides, disposal of silt & debris/grass/ rubbish up to 4 KM.**
2. The RCC drain has a length of 2000m. Cross section of the drain is enclosed.
3. The work of cleaning and maintaining the drains by removing the silt from the bottom, the weeds/ grass from the sides and clearing the side berms by stripping including disposal of silt/ rubbish/ grass/ debris to the disposal area pointed out by the Engineer-in-charge should be started from the date of commencement of contract and should be completed within a month as directed by the Engineer-in-Charge.
- 4. The removed silt from drains shall not be deposited in the sides of drain. The same shall be collected in trolleys and transported to the place pointed out by the Engineer-in-Charge and finally to the disposal area pointed out by the Engineer-in-charge.**

**SIGNATURE OF QUOTATIONER.**

## CROSS SECTION OF DRAIN

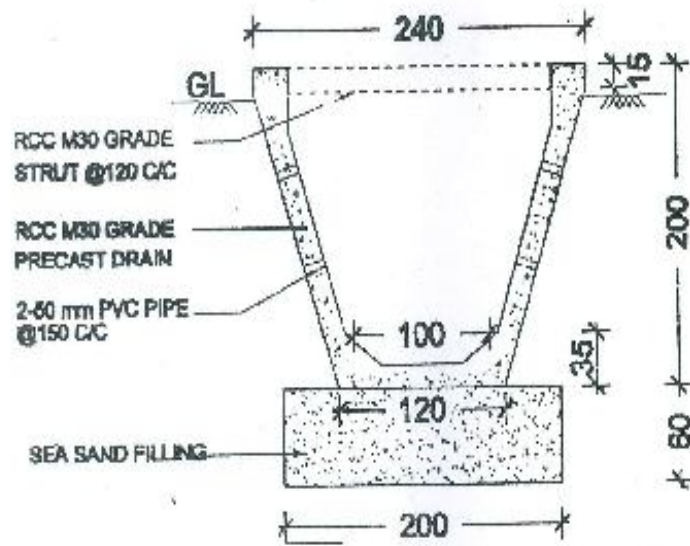

CROSS-SECTION OF RCC PRECAST OPEN DRAIN