



**COCHIN PORT TRUST**  
AN ISO-9001-2015 & ISPS COMPLIANT PORT

Office of the  
Senior Deputy Materials Manager  
Phone :0484-2667180  
Telefax :0484-2667180  
Email : sdmm@cochinport.gov.in;  
Website: cochinport.gov.in

**REQUEST FOR QUOTATION**

RFQ NO: F5/09/P-Bracket/2021-MM

Date: 18.09.2021

Electronic quotations are invited for supply of following item, subject to terms and conditions enumerated below.

Sl. No.	Description	Qty	Unit
1	<b>IRS approved Manganeeze Bronze P-BRACKET- as per drawing attached</b>  <b>Material : Manganeeze Bronze.</b>	<b>01</b>	<b>No.</b>

**Conditions:**

1. Quotation is due for opening on **27.09.2021**.
2. The bidders should have a valid digital signature certificate (Class-II or Class-III) issued by any of the valid Certifying Authorities to participate in the e-tender.
3. The bids should be uploaded in electronic form only through e-tender portal [www.tenderwizard.com/COPT](http://www.tenderwizard.com/COPT).
4. The bidders need to obtain one time User ID & password for log-in to e-tendering portal [www.tenderwizard.com/COPT](http://www.tenderwizard.com/COPT) from the service provider KEONICS, by paying registration amount of **Rs.1180/-** through online Payment using Credit/Debit Card/Net banking. The details of e-Tender facilitator is available through Telephone Nos. **080 49352000/9605557738**.
5. Price should be quoted in the price schedule, attached as a separate excel sheet in the e-tender portal.
6. Quotation will be opened at 15:00 hrs on **27.09.2021** in the e-tender portal [www.tenderwizard.com/COPT](http://www.tenderwizard.com/COPT). Tenderers can witness the quotation opening by logging in to the E-tender portal at the date and time fixed for quotation opening
7. RFQ should be signed and stamped on all pages by the bidder as a token of acceptance and to be uploaded in to e-tendering portal.

8. Price quoted should be for supply of "**P-Bracket**" at Cochin Port Trust Stores. The rate quoted should be inclusive of freight charges, duties etc: Terms like 'payable at actual', 'Extra as applicable' etc: should not be included in the offer.
9. **Manufacturing process should be done under IRS inspection/approval.**
10. **IRS Inspection charges will be borne by Cochin Port Trust.**
11. Drawing of P- Bracket is attached at page No.03.
12. Validity of offer: **60 days** from the date of opening of Quotation.
13. Rates quoted should be strictly as per unit specified.
14. GST rate (%) applicable for the product should be shown separately.
15. Tenderer should have GST registration.
16. Delivery Terms: F.O.R. Cochin Port Trust.
17. Delivery Period: Within **30** days from the date of receipt of purchase order.
18. Invoice shall be addressed to the Senior Deputy Materials Manager, Cochin Port Trust, Cochin – 682009.
19. Payment: 100% payment shall be made only after satisfactory supply of "P-Bracket"at site to the entire satisfaction of the engineer in charge at Cochin Port Trust.
20. TDS under GST Law: As per GST Notification No. 50/2018 dated 13.09.2018; TDS @ 2% will be deducted from any amount payable to the Contractor, where the total value of contract is more than Rs. 2.5 lakhs.
21. Cochin port Trust reserves the right to reject the quotation without assigning any reason.

Sd/-

**Sr. Dy. Materials Manager**

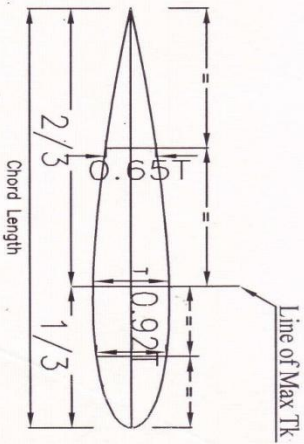
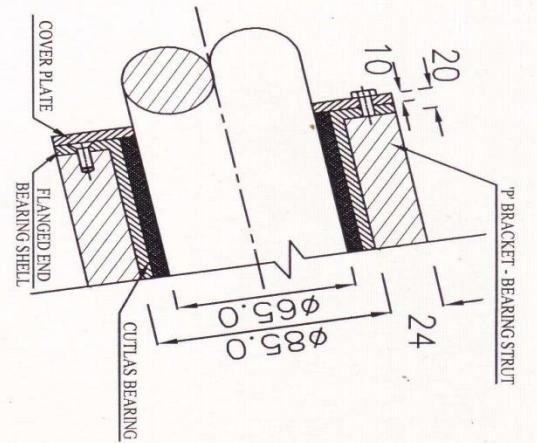
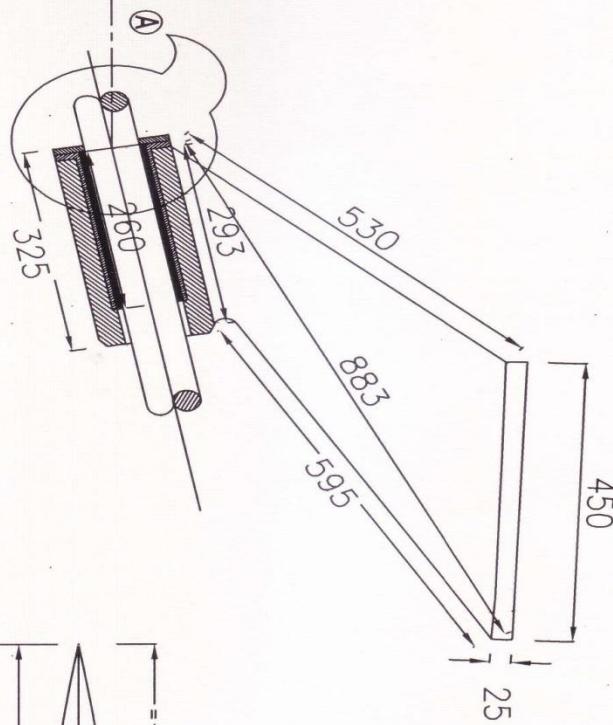
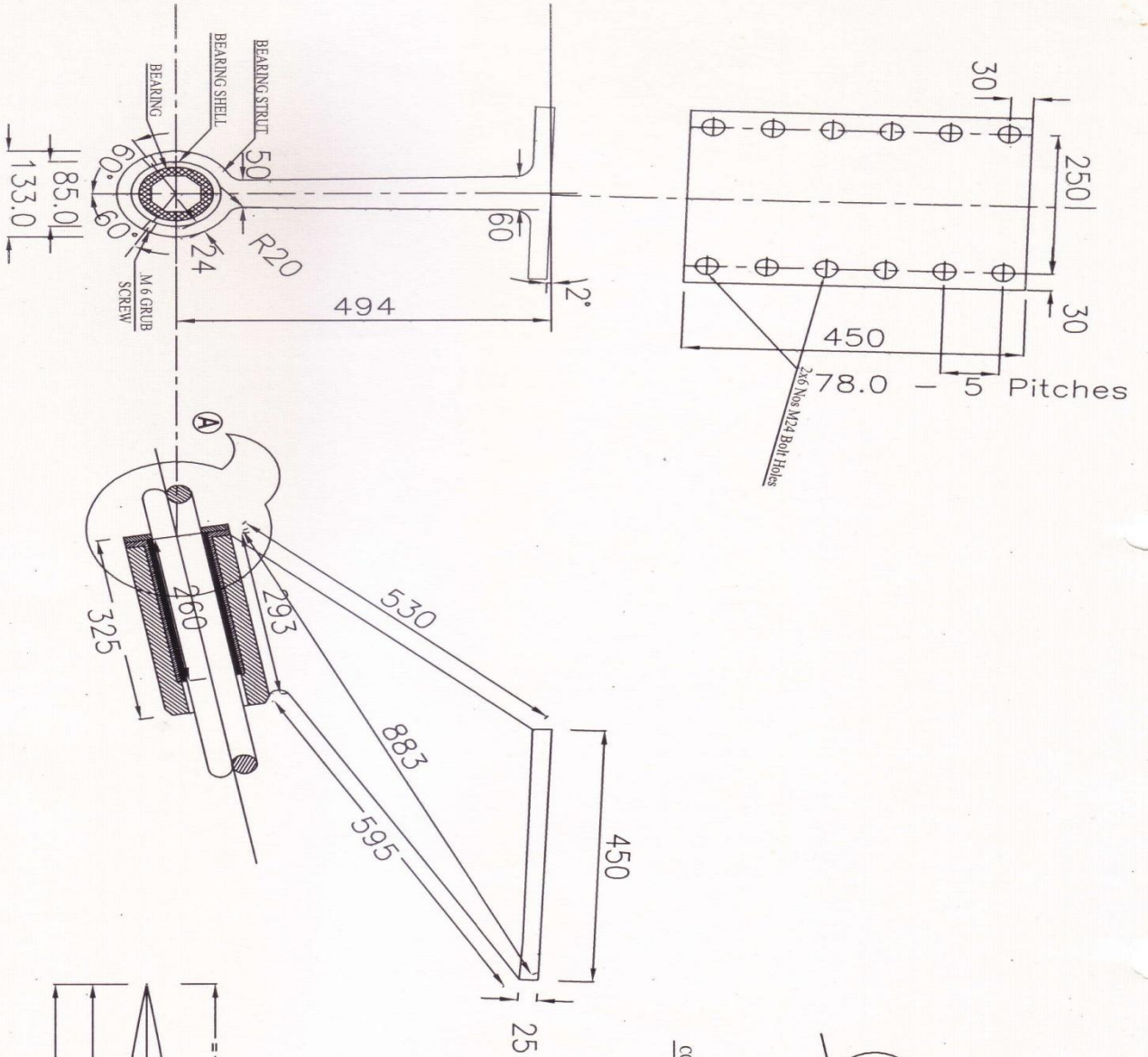

T - at Palm = 60  
T - at Boss end = 50

TYPICAL SEC THRO 'P' - BRACKET STRUT

**P - BRACKET DETAILS**

(MAT. OF CONSTRUCTION - Mn. BRONZE)

SCALE	ORIGINAL SIZE	DRAWING NO	SHEET NO	REV
1:10		24/AF/S-01	6/7	0